

TECNA®

S.p.A. - Via Grieco, 25/27 - 40024 Castel S. Pietro Terme - Bologna (Italy)
Pho. +39.051.6954400 - Tel. 051.6954410 - Fax +39.051.6954490
<http://www.tecna.net> - E-mail: sales@tecna.net - vendite@tecna.net

S P O T T E R

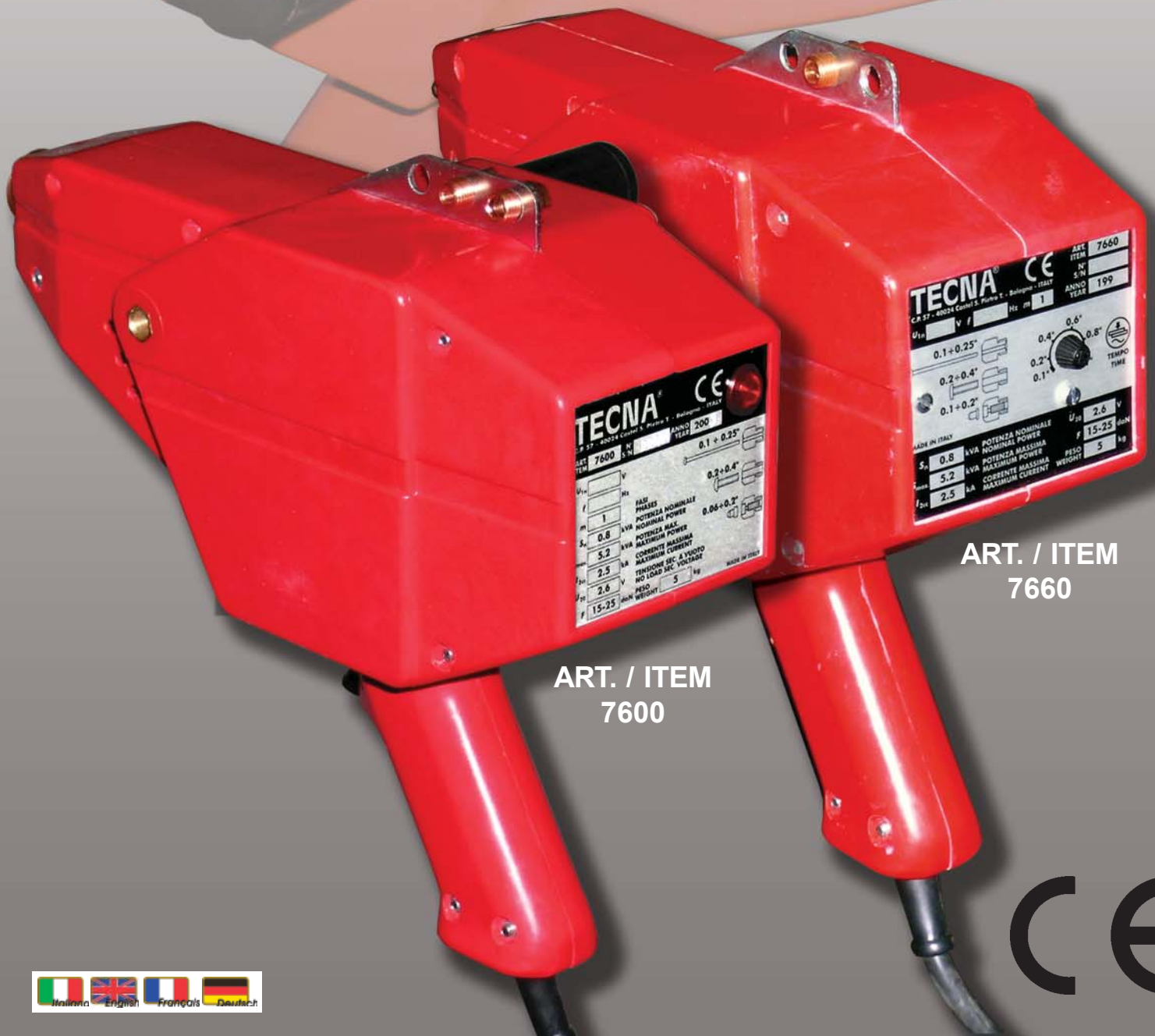

TECNA CE
C.P. 37 - 40024 Castel S. Pietro T. - Bologna - ITALY
ITEM 7600
ANNO YEAR 200
V_{eff} 1
f 50
P_n 0.8
S_n 5.2
I_{max} 2.5
U_{iso} 2.6
F 15-25
PESO WEIGHT 5 kg

0.1 + 0.25"
0.2 + 0.4"
0.1 + 0.2"
0.2 + 0.4"
0.06 + 0.2"
0.1 + 0.25"
0.2 + 0.4"
0.06 + 0.2"

FASE PHASES
POTENZA NOMINALE NOMINAL POWER
POTENZA MASS. MAXIMUM POWER
CORRENTE MASSIMA MAXIMUM CURRENT
TENSIONE SEC. A VUOTO NO LOAD SEC. VOLTAGE
PESO WEIGHT

ART. / ITEM
7600

TECNA CE
C.P. 37 - 40024 Castel S. Pietro T. - Bologna - ITALY
ITEM 7600
ANNO YEAR 199
V_{eff} 1
f 50
P_n 0.8
S_n 5.2
I_{max} 2.5
U_{iso} 2.6
F 15-25
PESO WEIGHT 5 kg

0.1 + 0.25"
0.2 + 0.4"
0.1 + 0.2"
0.4° 0.6° 0.8°
0.2° 0.1°
TEMPO TIME

MADE IN ITALY
POTENZA NOMINALE NOMINAL POWER
POTENZA MASSIMA MAXIMUM POWER
CORRENTE MASSIMA MAXIMUM CURRENT
TENSIONE SEC. A VUOTO NO LOAD SEC. VOLTAGE
PESO WEIGHT

ART. / ITEM
7660



Riduce i costi nelle autoriparazioni, evita di smontare pannelli interni e finiture, semplifica le riparazioni su parti scatolate, permette l'installazione delle modanature, irrigidisce le lamiere raddrizzate.

Cuts the cost on body repairs, no need to remove interior trims and fittings, double skin areas easily repaired, shrinking attachment for difficult dents and pimples, fits trim studs in seconds.

Réduit le coût des autoreparations, évite le démontage des panneaux intérieurs et finitions, simplifie les réparations sur les côtés doublés, permet l'installation de moulures, permet d'effectuer des retraits.

Reduziert die Reparaturkosten, vermeidet das Abmontieren der Innenwände und Fertigteile, vereinfacht die Reparaturen auf Kastenteilen, ermöglicht die Montage der Zierleisten festigt die geradegerichteten Bleche.

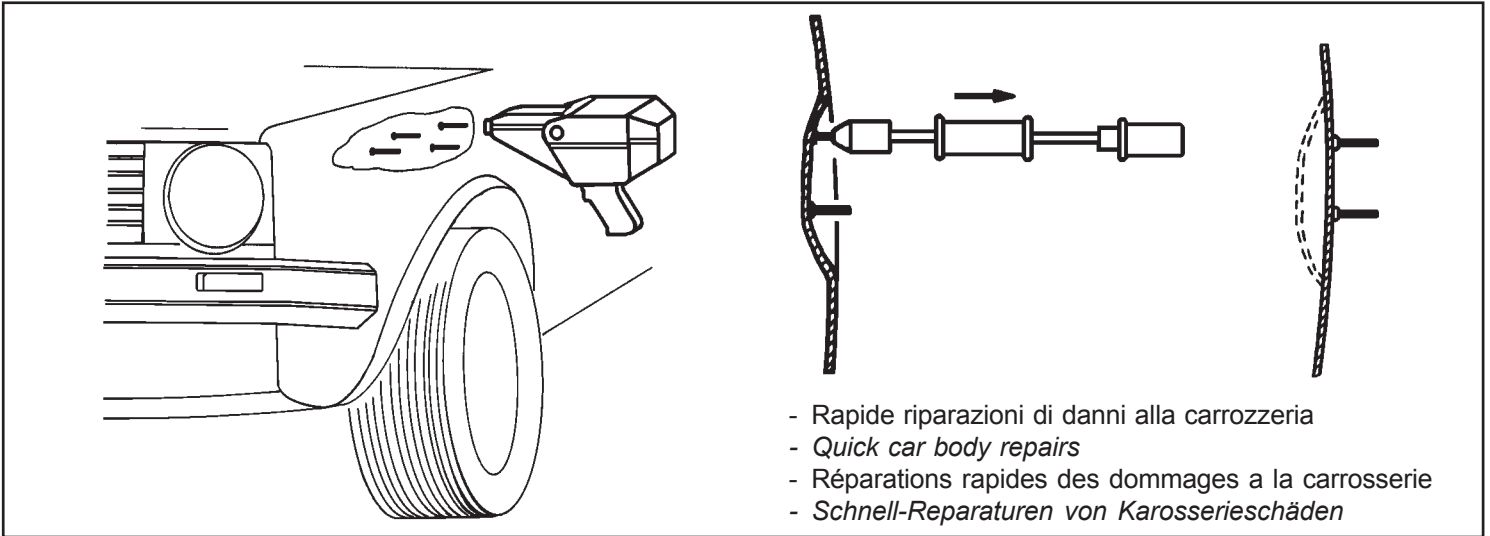

- Rapide riparazioni di danni alla carrozzeria
- Quick car body repairs
- Réparations rapides des dommages a la carrosserie
- Schnell-Reparaturen von Karosserieschäden

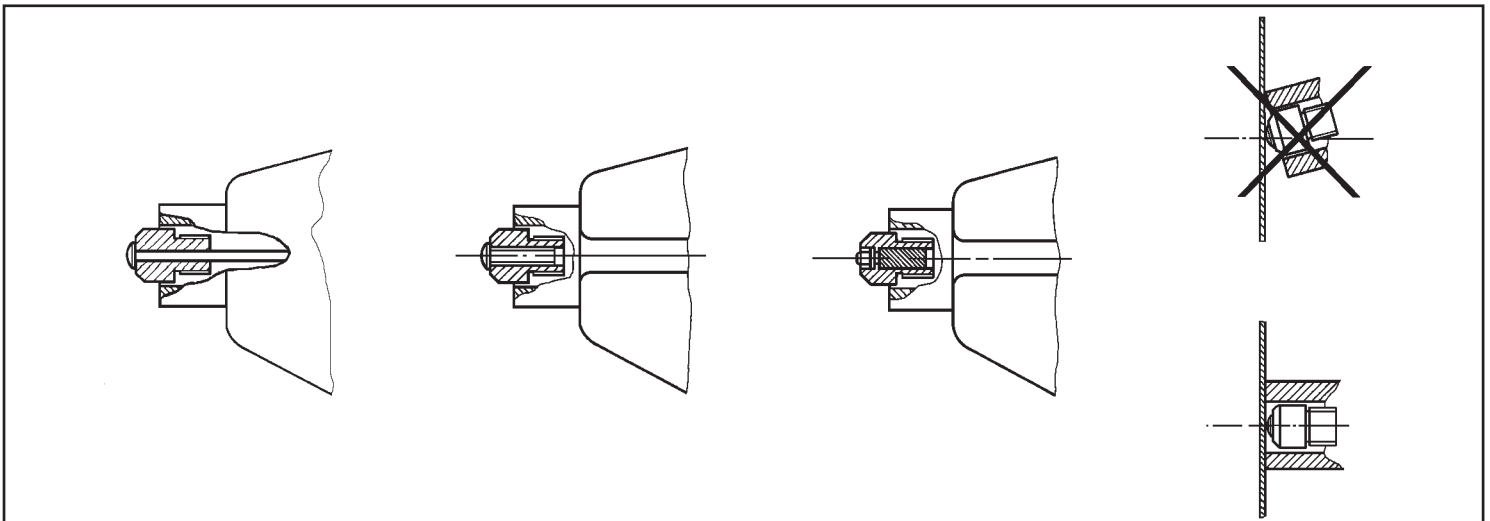

Per un corretto uso:

- scegliere l'elettrodo adatto al lavoro da eseguire,
- stringere correttamente l'elettrodo,
- realizzare il miglior contatto possibile,
- premere con forza moderata sulla lamiera.

For a correct use:

- Choose the electrode suitable for the work to be performed,
- Tighten the electrode properly,
- Obtain the best contact,
- Push with medium force on the sheet.

Pour un emploi correct:

- Choisir l'électrode adéquate,
- Serrer proprement l'électrode,
- Obtenir un contact correct,
- Presser le pistolet avec un effort moyen contre la tôle.

Für einen korrekten Gebrauch:

- die geeignete Elektrode für die auszuführende Arbeit wählen,
- die Elektrode korrekt anziehen,
- den bestmöglichen Kontakt schaffen,
- normal auf das Blech drücken.

Dati e caratteristiche	Features and data	Présentation et caractéristiques	Technische Daten		
Alimentazione Diverse a richiesta	Power supply Different upon request	Alimentation Differente sur demande	Netzanschluß Andere Spannungen auf Anfrage	V - Hz	220 - 50
Fusibile	Fuse	Fusibile	Sicherung	A	16
Potenza al 50%	Power at 50%	Puissance à 50%	Nennleistung 50% ED max.	kVA	0,8
Potenza max di saldatura	Max. welding power	Puissance max de soudure	Max Schweißleistung	kVA	6
Tensione a vuoto	No load voltage	Tension à vide	Leerlaufspannung	V	3
Corrente max di corto circuito	Max. short circuit current	Courant max. de court circuit	Max. Kurzschlußstrom	A	2500
Forza agli elettrodi	Force on electrodes	Force aux électrodes	Elektrodenkraft	daN	25
Dimensioni	Dimensions	Dimensions	Abmessungen	mm	280 x230x100
Peso	Weight	Poids	Gewicht	kg	5

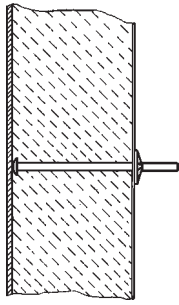

Installazione di pannelli di coibentazione
Noise and temperature insulation panels
 Panneaux isolants
 Installation von Isoliermaterial

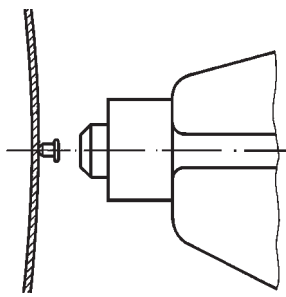

Rivetti per modanature
Trim rivets
 Rivets pour moulures
 Nieten für Zierleisten

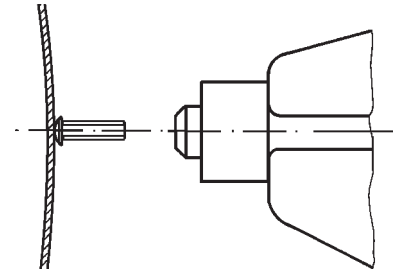

Saldatura di viti M4 per montaggio: cavi, tubi ecc.
Welding of M4 screws for fixing: cables, hoses etc.
 Soudage de vis M4 pour montages: câbles, tubes, etc.
 Schweißung von Gewindestiften M4 für Kabel, Schläuche usw.



Art. 7610

Art. 7611



Art. 7612



Art. 7613



Art. 7602

Elettrodo Ø 2,5
Electrode Ø 2,5
 Elektrode Ø 2,5



Art. 7603

Elettrodo Ø 4
Electrode Ø 4
 Elektrode Ø 4



Art. 7604

Elettrodo magnetico
Magnetic Electrode
 Electrode magnetique
 Magnetische Elektrode



Art. 7614



Art. 7608

Gancio per rondelle
Hook for washers
 Crochet pour rondelles
 Haken für Lochscheiben

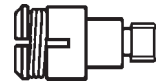

Art. 7605

Elettrodo per rondelle
Electrode for washers
 Electrode pour rondelles
 Elektrode für Lochscheiben



Art. 7607

Elettrodo per riscaldare
Electrode for heating
 Electrode pour retenir
 Elektrode zum Erhitzen

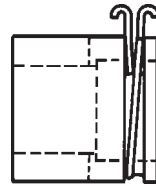

Art. 7606

Elettrodo comune a 7605 e 7607
Electrode for item 7605 and 7607
 Electrode pour art. 7605 et 7607
 Elektrode zu 7605 und 7607

* Alimentazioni diverse a richiesta
 * Power supply different upon request
 * Alimentation différente sur demande
 * Netzanschluß Andere Spannungen auf Anfrage

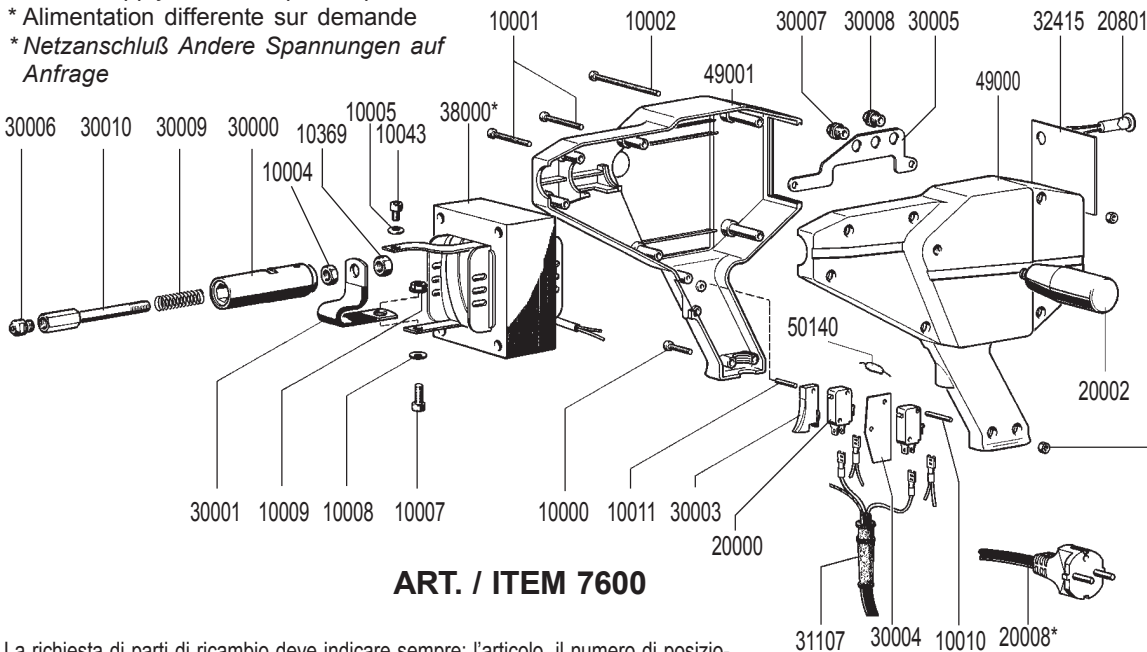

ART. / ITEM 7600

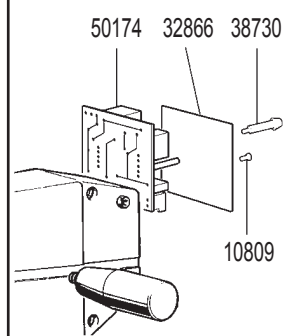

ART. / ITEM 7660

La richiesta di parti di ricambio deve indicare sempre: l'articolo, il numero di posizione, la quantità, la tensione, la frequenza e l'anno di fabbricazione.

In case spare parts are required please always state: the item, the position number, the quantity, the voltage, the frequency, the year and serial number.

En cas de demande de pièces détachées, indiquer toujours: l'article, le numéro de position, la quantité, la tension, la fréquence, l'année et le numéro de fabrication.

Bei Ersatzteilanfrage müssen immer der Artikel, die Positionsnummer, die Menge, die Spannung, die Frequenz, das Herstellungsjahr und die Herstellungsnummer angegeben werden.

Art./Item 7630/PL - 7690/PL

Art./Item 7630/CA - 7690/CA



Art. 7630	Art. 7690	Comprende:	Contains:	Est l'ensemble de:	Enthält:
Art. 7600		SPOTTER senza TIMER (Indicare la tensione e la frequenza)	SPOTTER without TIMER (state always voltage and frequency)	SPOTTER sans TEMPORISATEUR (Indiquer toujours voltage et fréquence)	SPOTTER ohne TIMER (Spannung und Frequenz angeben)
	Art. 7660	SPOTTER con TIMER (Indicare la tensione e la frequenza)	SPOTTER with TIMER (state always voltage and frequency)	SPOTTER avec TEMPORISATEUR (Indiquer toujours voltage et fréquence)	SPOTTER mit TIMER (Spannung und Frequenz angeben)
Art. 7601		Martello	Slide hammer	Tire-clous	Hammer
Art. 7602		Elettrodo Ø2 e Ø2,5 (montato sullo SPOTTER) Ø2,5 per saldature chiodi	Electrode Ø2 and Ø2.5 (fitted on SPOTTER) Ø2.5 to weld nails	Electrode Ø2 et Ø2,5 (monté sur le SPOTTER) Ø2,5 pour soudage de clous	Elektrode Ø2 und Ø2,5 (auf SPOTTER montiert) Ø2,5 für Schweißung der Bolzen
Art. 7603		Elettrodo Ø4 per viti	Electrode Ø4 for screws	Electrode Ø4 pour vis	Elektrode Ø4 für Gewindestifte
Art. 7604		Elettrodo Magnetico per rivetti montaggio modanature	Electrode Magnetic electrode for trim rivets welding	Electrode Magnétique pour rivet	Elektrode Magnetische für Nieten zur Montage von Zierleisten
Art. 7610		Chiodi Ø2x50 - Q.tà 100 pz	Nails Ø2x50 - Q.ty 100 pcs	Clous Ø2x50 - Q.té 100 pcs	Bolzen Ø2x50 - Packg. 100 Stk
Art. 7612		Viti M4x16 - Q.tà 100 pz	Screws M4x16 - Q.ty 100 pcs	Vis M4x16 - Q.té 100 pcs	Gewindestifte M4x16 - Packg. 100 Stk
Art. 7613		Rivetti per Modanature - Q.tà 100 pz	Trim rivets Q.ty 100 pcs	Rivets Q.té 100 pcs	Nieten für Zierleisten - Packg. 100 Stk
Art. 7614		Rondelle foro Ø8x16 - Q.tà 50 pz	Washers Ø8x16 - Q.ty 50 pcs	Rondelles Ø8x16 - Q.té 50 pcs	Lochscheiben Ø8x16 - Packg. 50 Stk
Art. 7605		Elettrodo per rondelle	Electrode for washers	Electrode pour rondelles	Elektrode für Lochscheiben
Art. 7606		Elettrodo di massa per Art. 7605	Electrode for Item 7605	Electrode pour Art. 7605	Elektrode für Art. 7605
Art. 7608		Gancio per Rondelle	Hook for washers	Crochet pour rondelles	Haken für Lochscheiben
Art. 20002		Impugnatura per SPOTTER	Handle for SPOTTER	Poignée pour SPOTTER	Handgriff für SPOTTER
Art. 7618		Scatola	Box	Boîte	Behälter
PL		Valigia in plastica	Carrying case in plastic	Valise en plastique	Plastikkoffer
CA		Valigia in cartone	Carrying case in cardboard	Valise en carton	Kartonkoffer
K		Valigia in plastica rigida	Carrying case in stiff plastic	Valise en plastique rigide	Kunststoffkoffer
		Peso complessivo 11.150 kg	Total weight 11.150 kg	Poids global 11.150 kg	Gesamtgewicht 11.150 kg
Art. 71276		Scatola (7618), confezione chiodi (7610), rondelle (7614), viti (7612), rivetti (7613), gancio (7608), Elettrodo per rondelle (7605)	Box (7618) for nails (7610), washers (7614), screws (7612), rivets (7613), Hook (7608), Electrode for washers (7605)	Boîte (7618) pour sachets de clous (7610), rondelles (7614), vis (7612), rivets (7613), Crochet (7608), Electrode pour rondelles (7605)	Behälter (7618) für Bolzen, Lochscheiben (7610), Gewindestifte (7614), Schraube (7612), Nieten (7613) Haken (7608), Elektrode für Lochscheiben (7605)

TECNA può variare senza preavviso alcuno, i propri prodotti. – TECNA specifications subject to change without notice. – TECNA Technische Änderungen vorbehalten.